

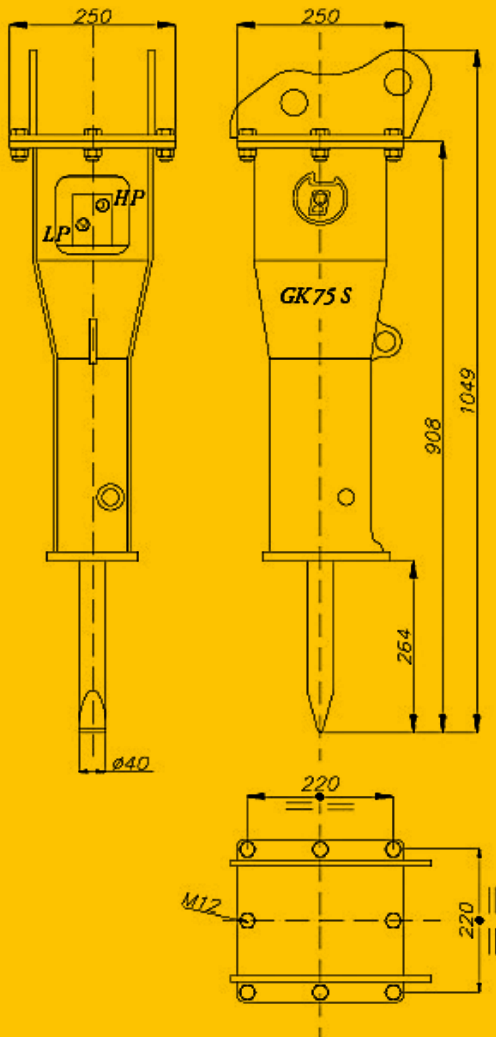

Italdem®



GK-75 S HYDRAULIC BREAKER

OPERATING WEIGHT	75 KG
TOOL DIAMETER	40 MM
OIL FLOW	13÷25 L/MIN
WORKING PRESSURE	95÷105 BAR
RELIEF VALVE	140 BAR
MAX BACKPRESSURE	12 BAR
BLOW ENERGY	160 JOULE
REQUIRED POWER	6 HP
IMPACT RATE	750÷1430
CARRIER WEIGHT	0,5÷2 TON
MAX NOISE LEVEL (SILENCED)	93 DB-A
INNER DIAMETER HP LINE	16 MM
INNER DIAMETER LP LINE	20 MM

www.italdem.com